

High Performance Software Defined Radio

Open Source Hardware and Software Project

Project Description: <http://hpsdr.org/>

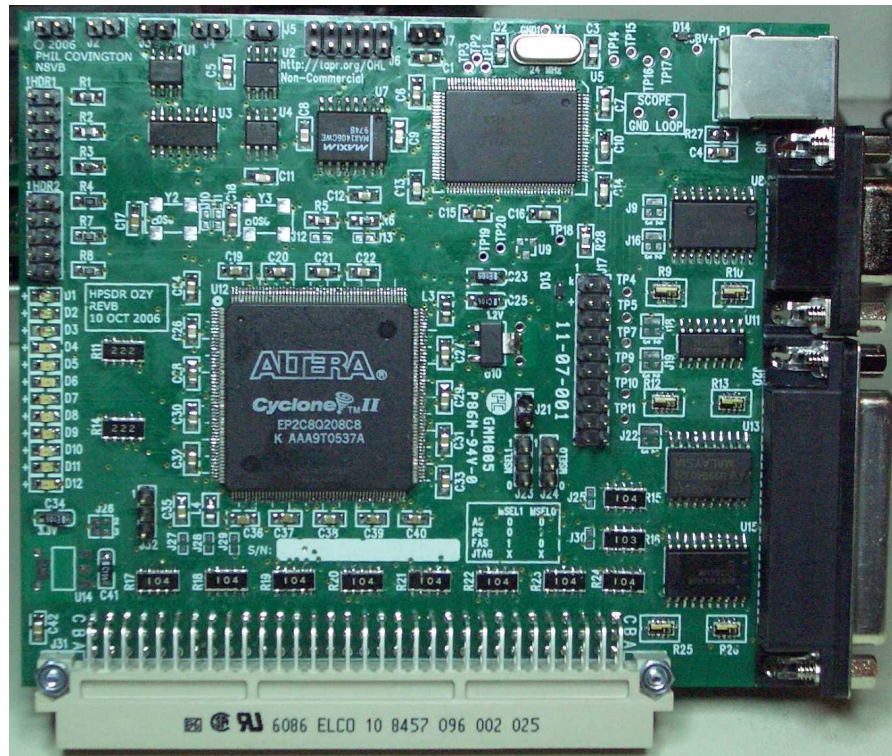

Hardware Project #3 **Ozymandias Board** Part #2 The Making of OZY

Graphics und Layout
Project Coordinator
Board Design

Horst Gruchow, DL6KBF
Phil Covington, N8VB
Phil Covington, N8VB



Chapter 1: Preliminaries

1.1 Physical and mental preparation

Before you start building anything please check yourself regarding your personal physical and mental condition. You should ask yourself if you are physically so well that you could start such a project. If you are hyperactive or have problems with tremor in your hands I would recommend that you find another day to start or even stay away from this and buy a finished board.

If you just had a fight with your wife or your boss and you are still very angry or frustrated inside please don't start soldering. You definitely will throw all the tiny parts on the floor and can't find them anymore.

How you should be:

- in a good health condition
- in a goooooood mood
- calm and cool inside
- have self-confidence

You should be knowing what you are doing!

You also should be familiar with the basic SMT soldering techniques!

1.2 Workbench preparation

1.2.1 Table

The work table should be totally cleaned up and emptied before starting any work on OZY. This makes it easier to find any part which possibly jumps off the tweezers.

1.2.2 ESD (ElectroStatic Discharge) prevention

Since most of the ICs on OZY are very sensitive to ESD it is recommended that you use an ESD matt. This should be connected at least to the solder station ESD connector.

Before touching any IC you should place both hands flat on the matt in order to discharge yourself. Alternatively wear an ESD strap around your wrist which is connected either to the matt or to the same potential as the matt.

I use an ESD matt of about 60x50 cm² which is fairly cheap (approx. 15 EUR). It is made from PVC which has the advantage of also having an anti-slip surface. I am usually placing the PCB directly on the matt without using any vise. This makes the PCB handling very easy and convenient.

The HPSDR High Performance Software Defined Radio has become one of the most attended HAM Radio projects worldwide.

Since ATLAS, JANUS and OZYMANDIAS boards are out supporting the FLEXRADIO® SDR-1000 transceiver audio processing an overwhelming amount of people have ordered the whole set of finished boards for their radio.

Surprisingly enough also bare PCBs have been sold in quite good numbers. That's where this documentation kicks in. People should not be left alone with their boards even if they are experienced builders. This whole project is very complex also from the parts point of view and requires exact preparation in order to avoid mistakes. If you make only one it can be kind of difficult to find it.

But enough words, just let's have fun. That's what this is all about.

73
Horst
DL6KBF

Chapter 1: Preliminaries

1.3 Soldering tools

For this type of project a good quality soldering tool is very essential. Preferably a soldering station with electronic temperature control and a wattage of around 50W to 80W should be used.

- forget about cheap irons. They are too hot.
- forget about so-called SMD soldering needles. They usually have around 8 watts which after my experience is useless.

Most important:

Buy the finest solder tip for your iron which you can get. Mine has a tip diameter of 0.2 mm (around .01 inch). This is suitable for soldering even the fine pitch CPLD.

Alternative methods include various kinds of reflow or hot air soldering techniques. You can find many details about reflowing or hot air soldering on the internet in the various microcontroller forums or on some HAM websites.

But be warned:

I tried to reflow OZY with my temperature controlled pizza oven and I had a very bad experience with the board delaminating despite the correct temperature profile.



That's what I am using

as small as possible. I am using a wire diameter of 0.5 mm. If you can get a smaller wire diameter this should be even better. In Europe the readily available minimum diameter is 0.5 mm.



Solder containing lead

1.3.1 Solder wire

With solder wire you have the choice of using wire containing lead or the new lead-free (RoHS compliant) solder wire. Leaded solder wire is still available and you do not need to change your soldering habits which you most probably have developed over the years.

Lead-free solder wire has the disadvantage of a higher melting temperature which you have to get used to. So, if you decide to use lead-free solder wire please do some test soldering before getting on OZY.

Very important:

The diameter of the solder wire should be



Lead-free solder

Chapter 1: Preliminaries

1.3.2 Solder Flux

Actually my personal experience with solder flux is twofold:

- it is a fantastic aid for soldering
- depending on the kind of flux it bears some danger of getting bad solder joints and it makes the board look ugly

My experience:

In the beginning I had been using a flux with kind of a jelly texture. It is sold under the name '**solder honey**' and is very sticky. The ICs could be positioned very easily and stayed at their position. But after soldering you could not clearly see the pads anymore in order to check the soldering quality. It also did not dissolve with isopropyl alcohol so that the board looked ugly.

My recommendation:

For the OZY board with its pre-tinned pads you should better use a water-clear no-clean flux and you will only need it to solder the two fine-pitch ICs U5 and U12. The other ICs and components can be soldered fine without using any flux at all.

I am using a solder flux stick as shown in the next picture.



No-clean water-clear solder flux

1.3.3 Solder Wick

This is what you actually need in a good quality and probably a good quantity of it.

It should be of a fine diameter (0.8 mm) for IC pins and about 1.5 mm diameter for other solder joints.



Solder Wick

1.4 Essential tools

Besides the soldering iron this project requires some other specialized tools. You may get along without them but they make life much easier and they are not too expensive. Some of them look like dentist tools and they actually are. So all the HAM dentists out there have an advantage: they can bring home their tools from work. But don't use them for your patients anymore afterwards!

1.4.1 Tweezers

This will be your main tool besides the soldering iron and it should be of excellent quality. The tweezers should be specialized for SMD work and should be stainless steel.



This is what I am using

This model for me is the most convenient one because it has this 30 degree angle and the two little pads at the tips. Others may have other preferences.

Additionally you should have at least one

Chapter 1: Preliminaries

extra pair of tweezers with acute tips, either straight or angled.



They may look like this

1.4.2 Dentist tools

As mentioned before these tools are very helpful for manipulating parts (especially ICs), cleaning the PCB and probing the quality of solder joints on IC pins. You can get a set of these in acceptable quality for a good price.



1.4.3 What else?

What I am also using are sewing machine needles. You can also use hand sewing needles but household sewing machine needles are more readily available.

So, during your next stop at the convenience store get yourself a pack of sewing machine needles. Microtex needles are to be preferred because they have a sharp tip.

What do I do with them?

The needles have a nice nickel plated surface. So you can solder some wire on them and use them as fantastic probes.

Connected to your multimeter in audible continuity test you are able to touch every single pin of a fine-pitch IC right where they come out of the case and use the second needle probe to touch the pad below the pin or even penetrate through the solder mask lacquer and touch the copper traces in order to verify continuity.

They are a nice and inexpensive tool and I love them (because my company makes them, hi).

Once the tip is worn off just take another set.



Chapter 1: Preliminaries

1.5 Last and most important

Vision

Personally I am nearsighted (-6 diopters). So what I am doing is take out my contact lenses, put on **safety glasses** and stick my nose very close to the PCB. Then I have a beautiful and clear view on all the soldering pads.

For the fine-pitch ICs this is still not enough. You should definitely have some kind of magnifying glass with at least a 5x magnification.



A higher magnification is not useful because then you do not have any working distance under the magnifying glass anymore.

The best tool to use is a microscope with 10x and 20x magnification or even a zoom lens.

This is what I am using:



I got a very good bargain on a second-hand one on the internet and this is the best tool I ever bought. It has 10x, 20x and 35x magnification and a work distance of 160 mm with 10x magnification.

The technical data can be viewed at <http://www.euromex.nl>.

I also have got a USB microscope camera but the disadvantage with this camera is that even with 10x magnification the camera is too close to the board. There is no real workspace under it anymore.

Jason, N8INJ, has reported of having used a cheap webcam:

"...One other idea you may want to share with others is that if a microscope is out of their price range there are some other ways to get more magnification. Possibly the simplest is to use a "webcam" on your computer - most of them are capable of very close focusing out of the box (though some may require minor adjustments to the lens) and can give a good deal of effective magnification cheaply. It's usually also possible to tape a loupe over the lens to get even more magnification. ..."

Chapter 1: Preliminaries

1.5 Soldering techniques

On the internet you can find numerous pages with information on soldering fine-pitch ICs

A good information source is

<http://www.solder.net>

where they have some training videos from time to time which you can download.

Training on old computer boards is also helpful in getting some soldering skills for fine-pitch ICs.

But I am sure that everybody who has ordered the bare OZY board has understood as well that this is not one of the easiest hobby projects.

And now let's start.

**Enough preliminaries.
Let's heat up the soldering
station and
DO IT.**



Chapter 2: How to start

2.1 Getting organized

According to a little statistic which I calculated you are now sitting in front of 133 parts plus the PCB and you are expected to get ready to do approx. 700 solder joints. This makes it clear that OZY is not just a little sunday afternoon project.

As a little side project I have developed a modified BoM (Bill of Materials) for JANUS which can be downloaded from my website:

[OZY-BOM-Organizer](#)

In this organizer the parts are grouped in the same sequence as they will appear in this document

Chapter 2: How to start

2.2 Don't panic at hundred pins and more

After roughly aligning the chip on the pads (don't be afraid of touching the IC with your fingers if working on an ESD matt) put a pair of tweezers or a similar tool on the chip as a load. Another method which I use very often is to put a thin layer of solder honey on the pads. This makes the pads sticky and the IC can't barely move anymore. In this way it can be aligned properly.

Using the tweezer method I take the soldering iron in one hand, press one finger on the tweezers and with the soldering iron I touch a corner pin of the IC. The tin on the pad (with pre-tinned pads) mostly is enough to tack down that pin on the pad.

Again you should check the correct placement of the chip on the pads and then tack down the corner pin diagonally across the first soldered pin.

If everything fits well I usually solder pin by pin around the IC.

If by accident you use too much solder and make a short between two pins just use the solder wick to remove the excess solder.

Don't be too anxious. In a reflow oven the chip withstands temperatures of 240 °C for minutes.

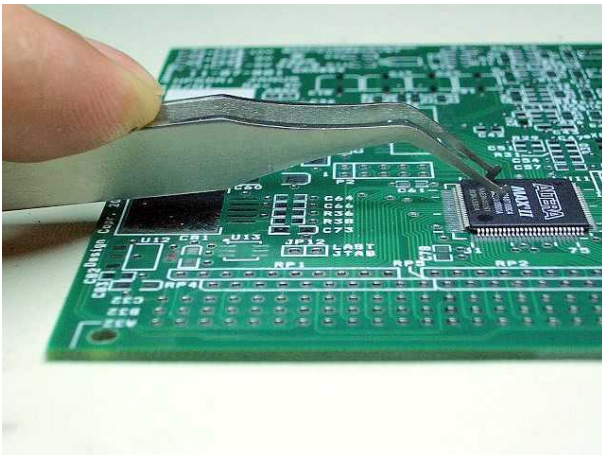
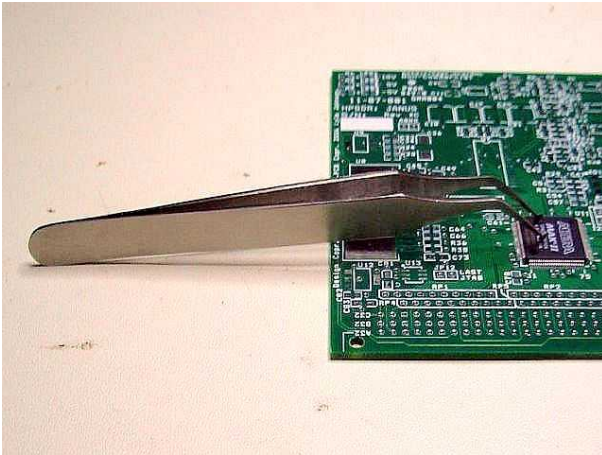

Chapter 3: Parts Placement

Now we start placing the parts on the board.

The following step-by-step method should make it possible for everyone to populate the board in such a way that it will work immediately. We start with the ICs and then go from 'low' to 'high' parts in the order of their values.

So first you should place and solder all the ICs onto the board. The positions on the board are self-explanatory. Just make sure that you always position them the correct way.

Have fun!!!



CAP 0805; 100n	
Item 1	
Position	Reel
C01	
C04	
C05	
C06	
C07	
C08	
C09	
C10	
C11	
C12	
C13	
C14	
C15	
C16	
C17	
C18	
C19	
C20	
C21	
C22	
C24	
C26	
C27	
C28	
C29	
C30	
C31	
C32	
C33	
C35	
C36	
C37	
C38	
C39	
C40	
C42	

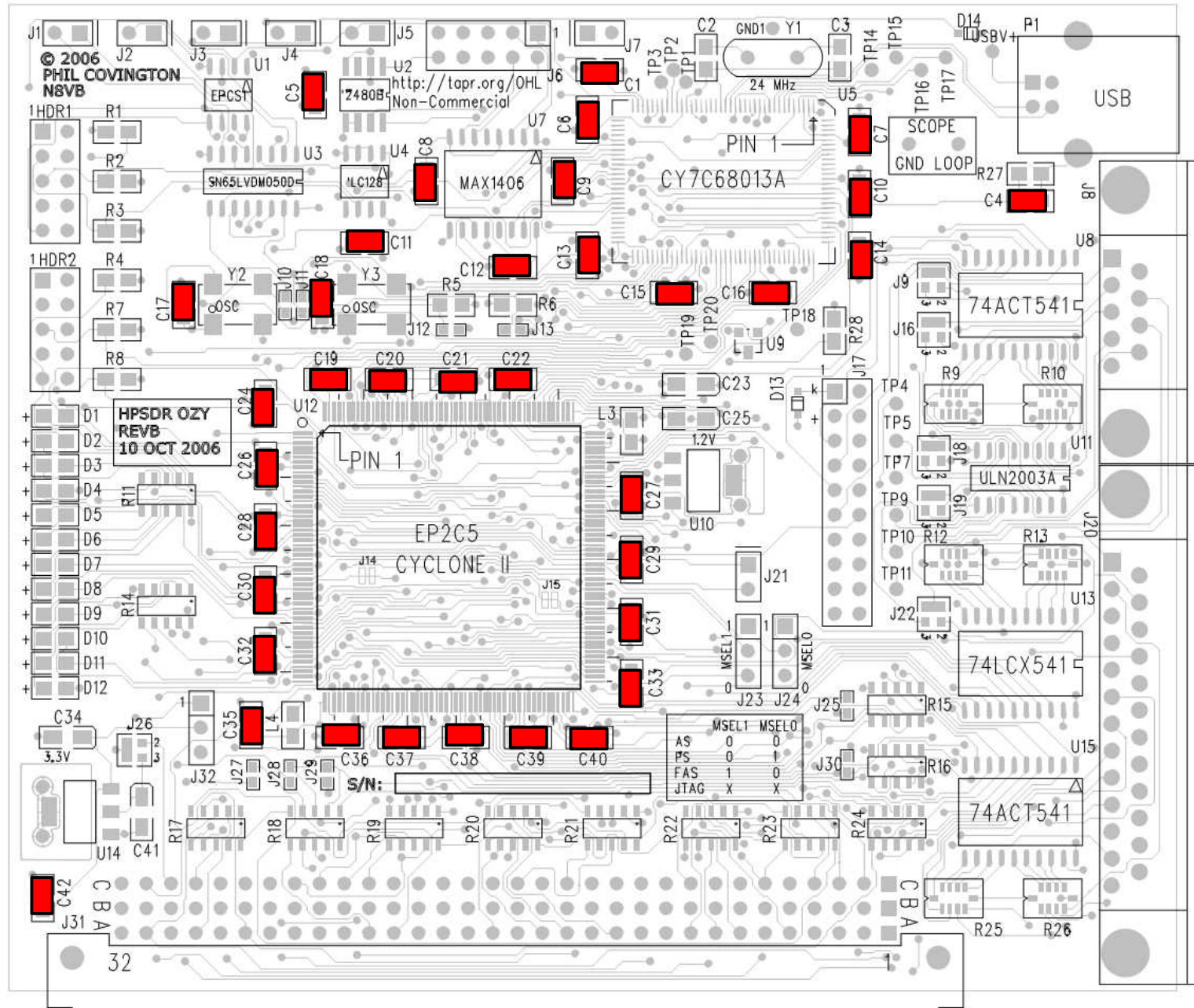



CAP 0805; 12p	
Item 2	
Position	Reel
C02	
C03	



RES 0805; 10M	
Item 6	
Position	Reel
R27	



RES 0805; 1k	
Item 7	
Position	Reel
R04	
R07	
R08	



RES 0805; 10k	
Item 5	
Position	Reel
R01	
R02	
R03	
R05	
R06	
R28	

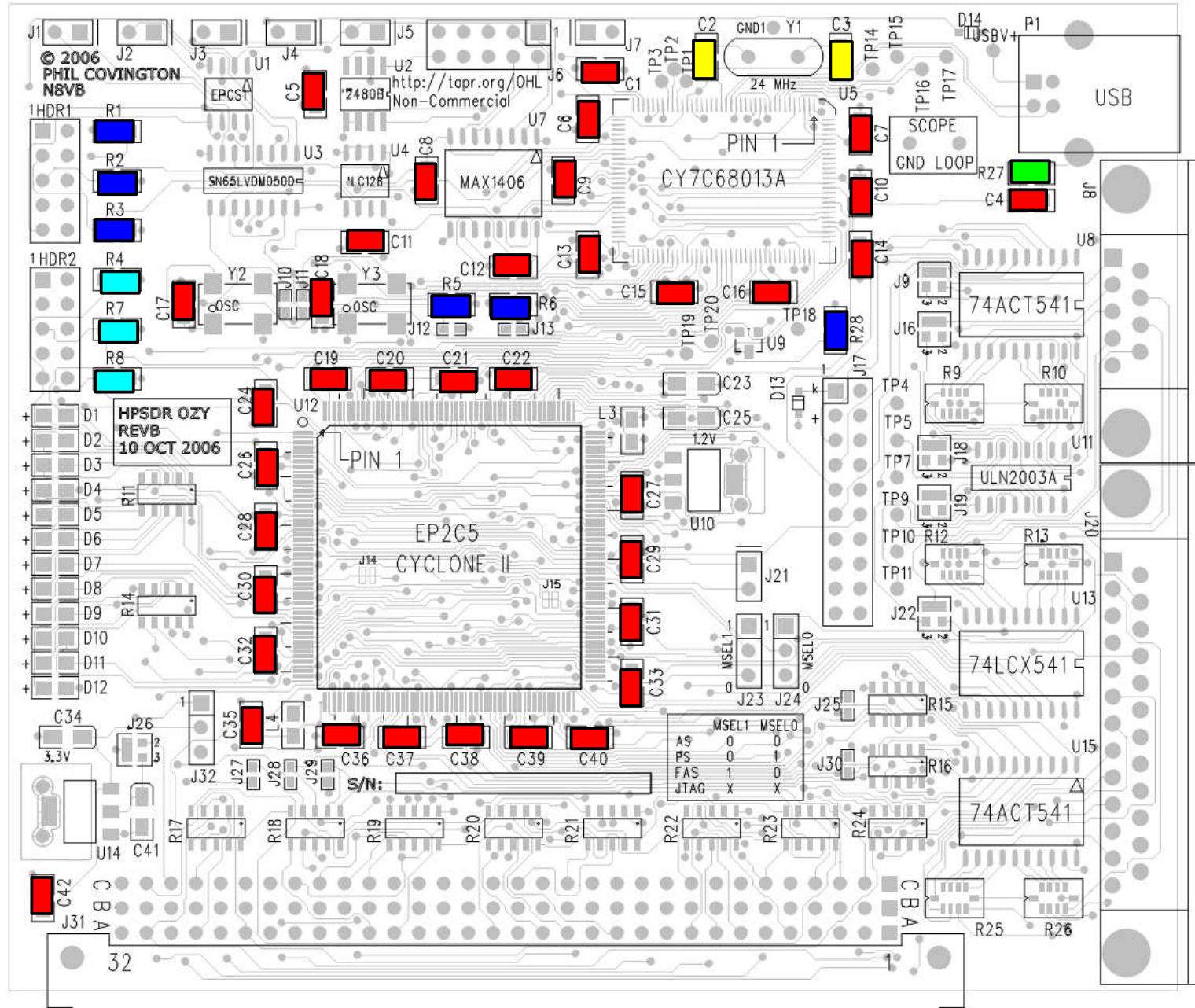

Tantal 3216; 1uF/25V	
Item 3	
Position	Reel
C23	
C34	



Tantal 3216; 10uF/10V	
Item 4	
Position	Reel
C25	
C41	



Ferrite chip 600Ohm	
500mA 0805	
Item 15	
Position	Reel
L3	
L4	



BAT43 30V, 0,2A	
Item 13	
Position	Reel
D13	
D14	

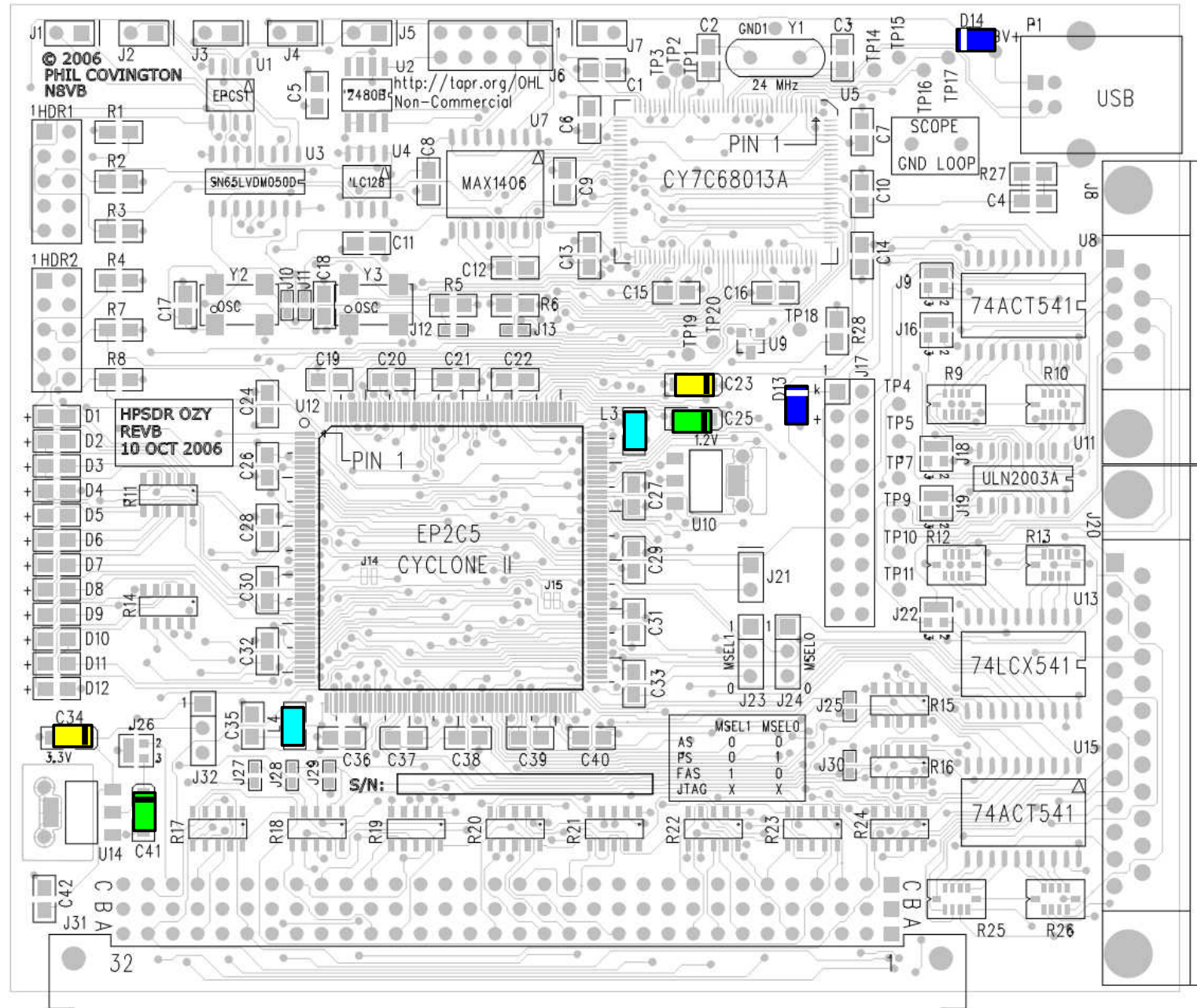

Special Instructions: Placing LEDs 1 to 12

How to determine the polarity of the 0805 LEDs?

It can be difficult to find out the polarity of the tiny 0805 LEDs if you don't know what to look for.

The Lite-ON® LEDs used in the OZY BOM are easy to determine the polarity. Looking on them under a magnifying glass you can see that the LED dice (photo) is visible and off-center from the body. This is the anode (+) side which has to match with + on the PCB.

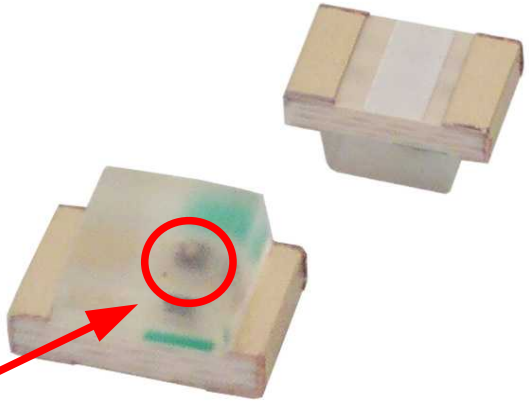

LED Dice

The ones which I am using have a little mark printed on the bottom:

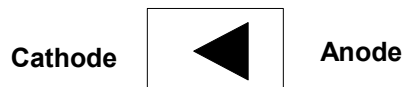
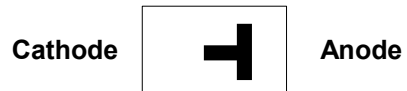



Item 14	
Position	Reel
D01	
D02	
D03	
D04	
D05	
D06	
D07	
D08	
D09	
D10	
D11	
D12	RED

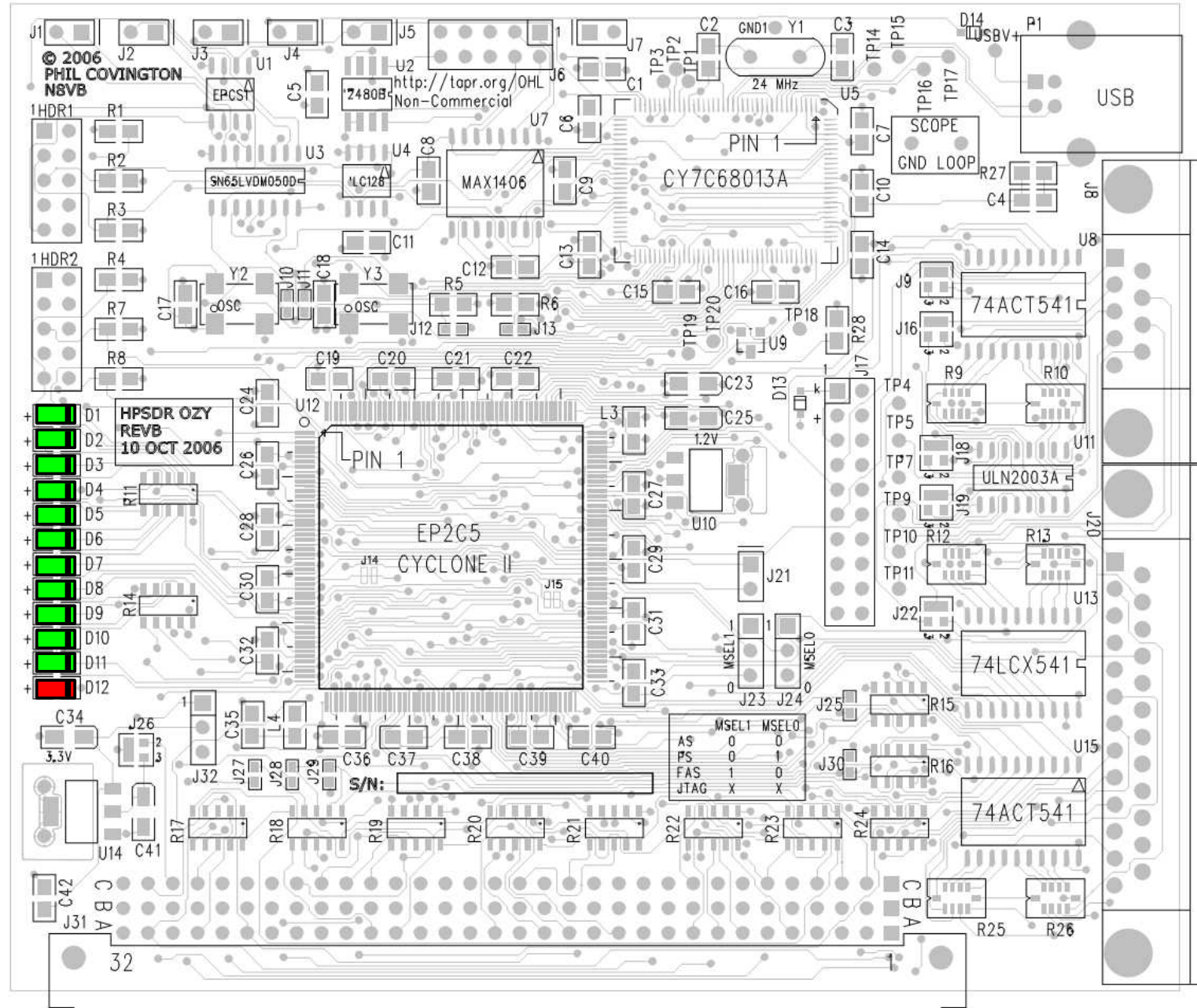
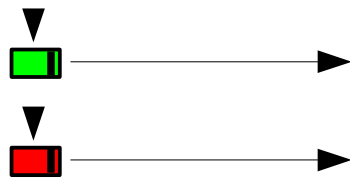



Pana EZA-ST13AAAJ 22R
100pF
Item 8

Position	Reel
R09	
R10	
R25	
R26	



Pana EZA-ST33AAAJ
100R 100pF
Item 9

Position	Reel
R12	
R13	



Pana RP-Bus 8x10k EXB-A10P103J
Item 12

Position	Reel
R16	

Pana RP-Bus 8x2.2k EXB-A10P222J
Item 11

Position	Reel
R11	
R14	

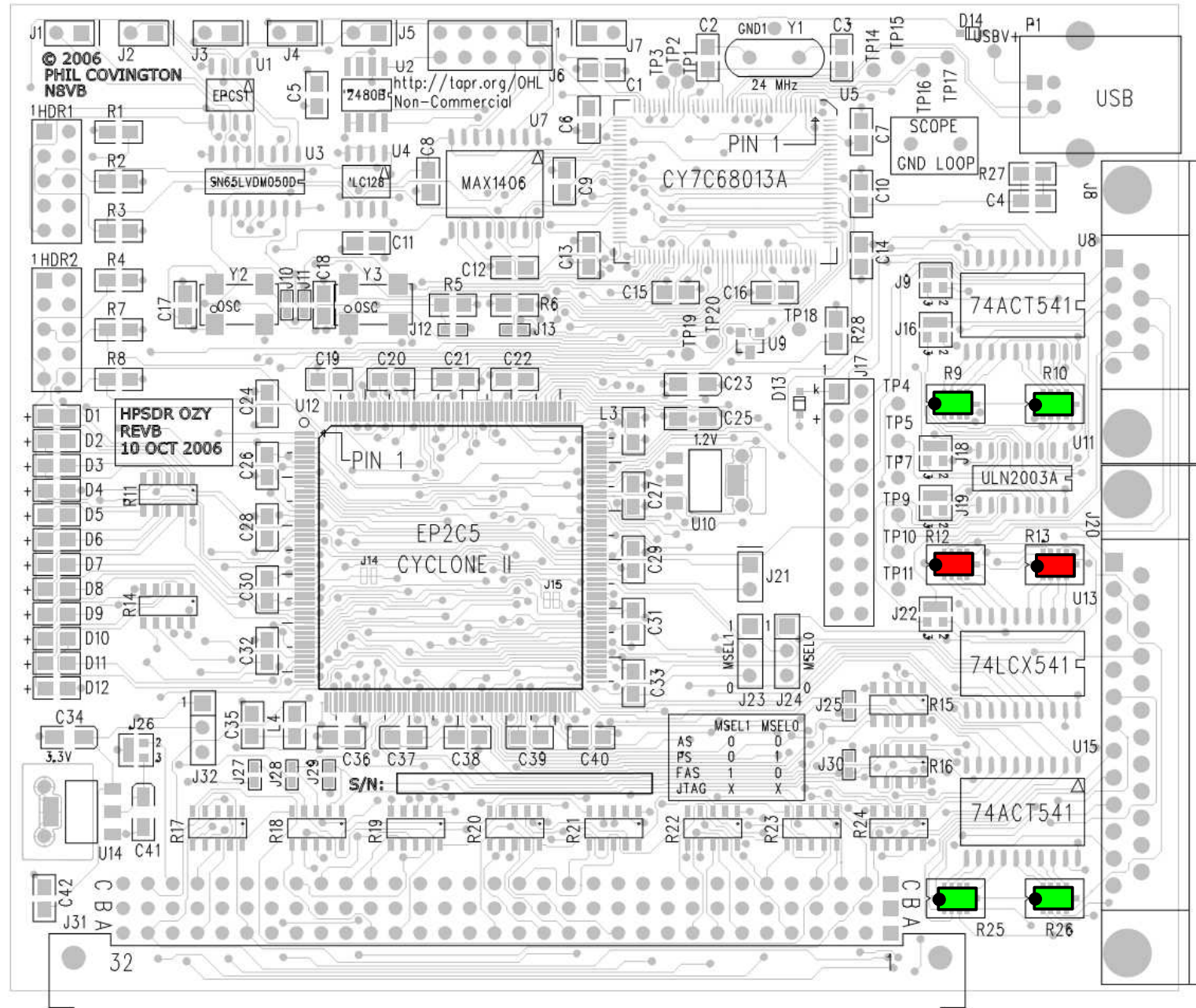



Pana RP-Bus 8x10k EXB-A10P103J
Item 12

Position	Reel
R16	



Pana RP-Bus 8x2.2k EXB-A10P222J
Item 11

Position	Reel
R11	
R14	



Pana RP-Bus 8x100k EXB-A10P104J
Item 10

Position	Reel
R15	
R17	
R18	
R19	
R20	
R21	
R22	
R23	
R24	

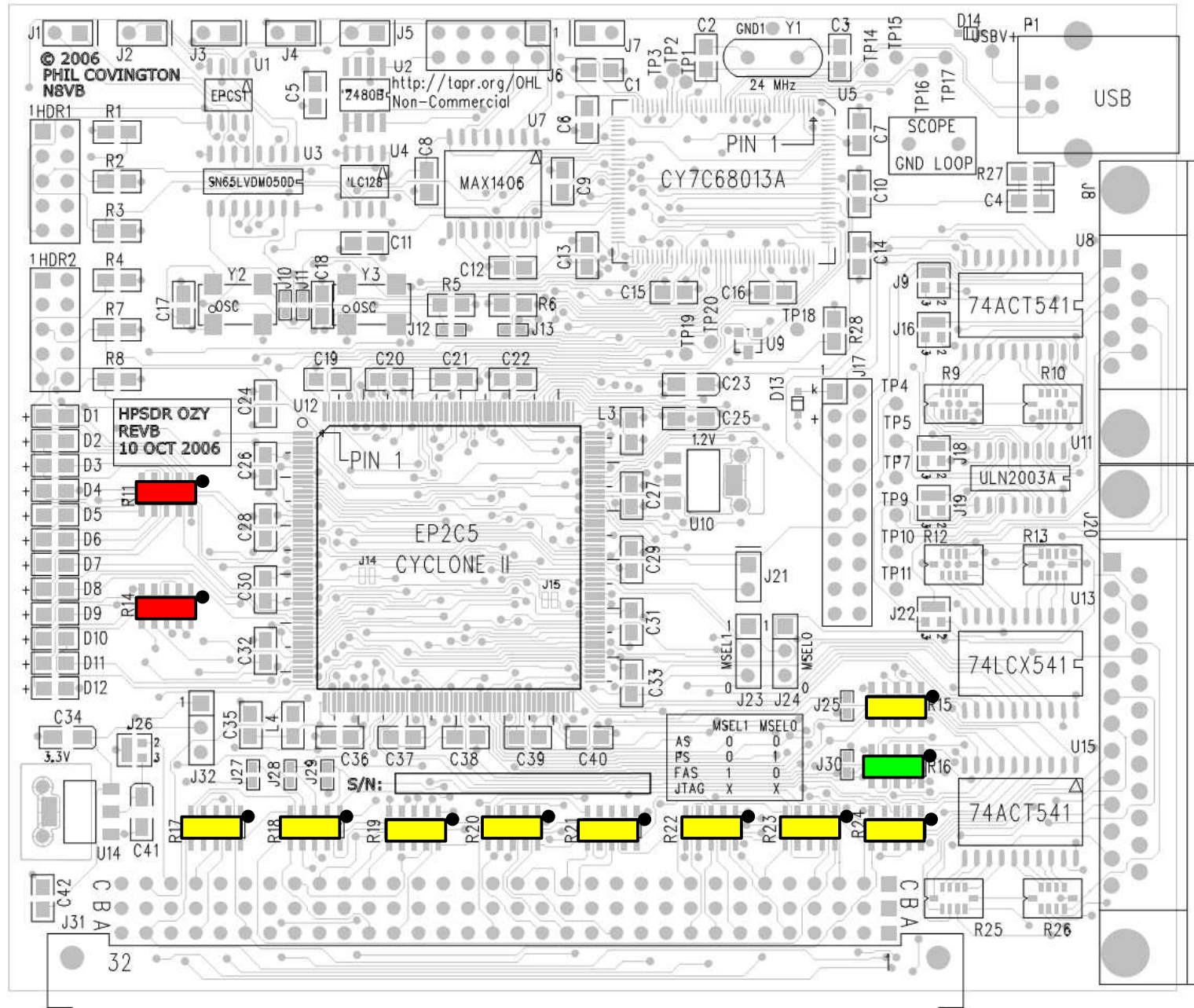

Tantal 3216; 1uF/25V

Item 3

Position	Reel
C23	
C34	



Tantal 3216; 10uF/10V

Item 4

Position	Reel
C25	
C41	

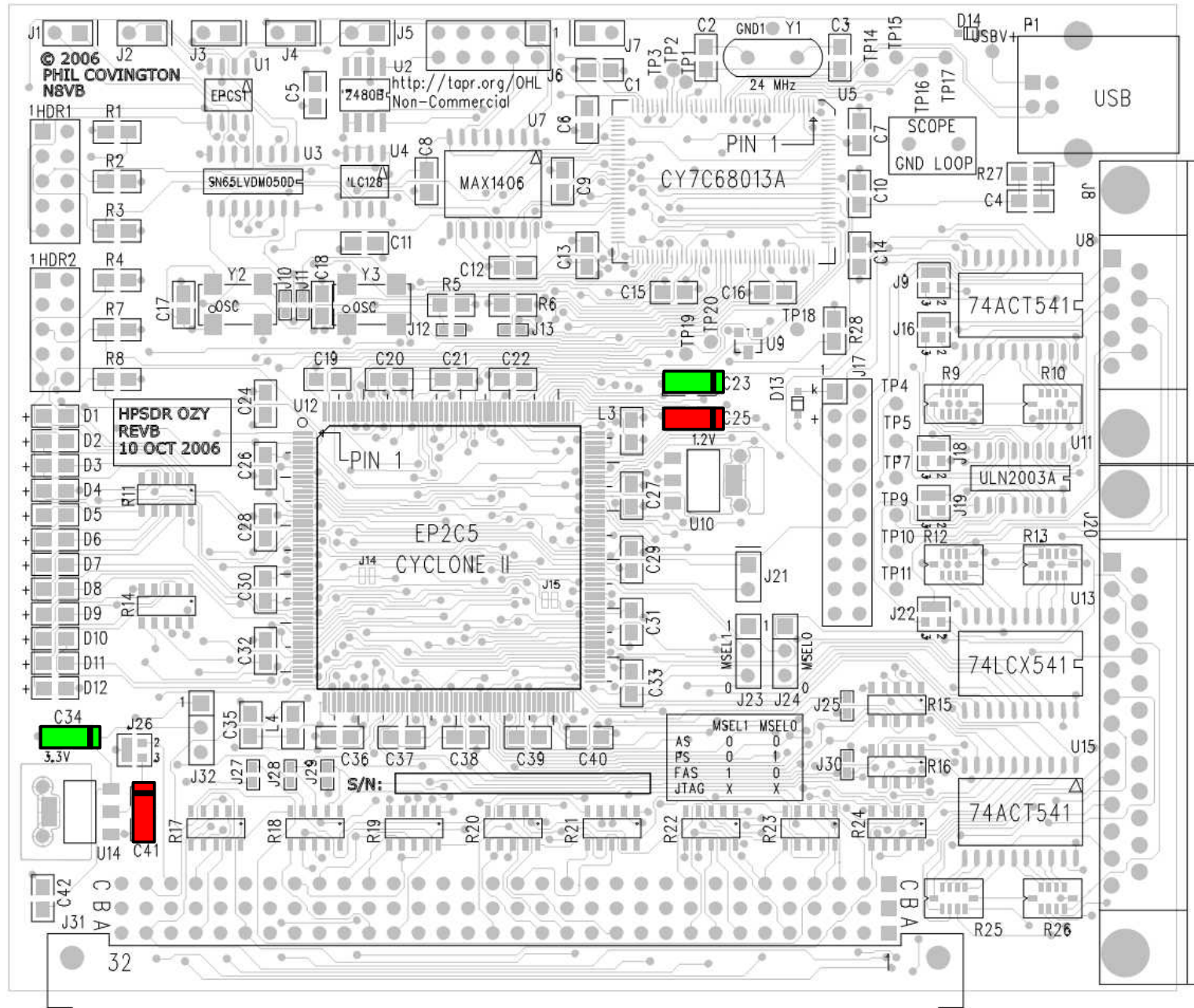

Default Jumper Settings

